

Motorized 2 Pcs FEP / PFA Lined Ball Valve Flanged End

Pneutork make electrical on/off, modulating, integral starter actuator operated investment casting WCB/CF8/CF8M 2 pcs design PFA/FEP lined ball valve For optimum solution for corrosive Application.

SIZE RANGE · 1" TO 4" Flanged end

Test Pressure

Pressure Test	As per Customer Requirement
Spark Test	15KV D2, API 598

Standards

Design and Manufacturing	BS EN ISO 17292 : 2004 (BS 5351)
Valve Face to Face Dimension	ANSI B16.10/ DIN 3202 / BSEN
Flange Standard Conformity	558 - 1/2 ASME B16.5 Class 150
Inspection & Testing	BS EN 12266 - 1 & 2 (2003) API -598
Top Flange Drilling	ASA 150# / DIN 2632 & 2633 / BSEN 10 TABLE D, E, F (Customer Specified)

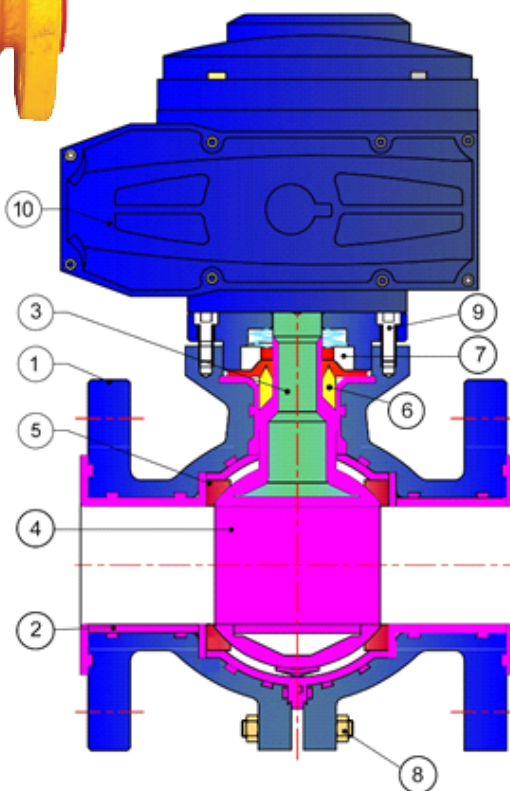
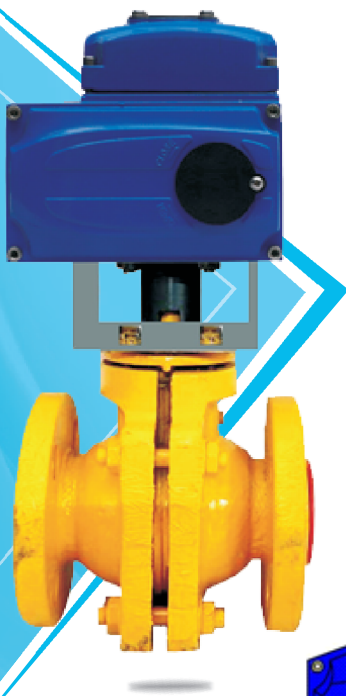

No.	Description	Material
1	Body	WCB / CF8 / CF8M / S.G. IRON / D.I.
2	Body Molding	FEP / PFA
3	Ball With Shaft	WCB / CF8
4	Ball Molding	FEP / PFA
5	Ball Seal	PTFE / GFT / CFT
6	Shaft Bush	PTFE / GFT / CFT
7	Packing Washer	Spring Steel
8	Nut	S. S.
9	L. N. Bolt	S. S.
10	Electrical Actuator	STD.

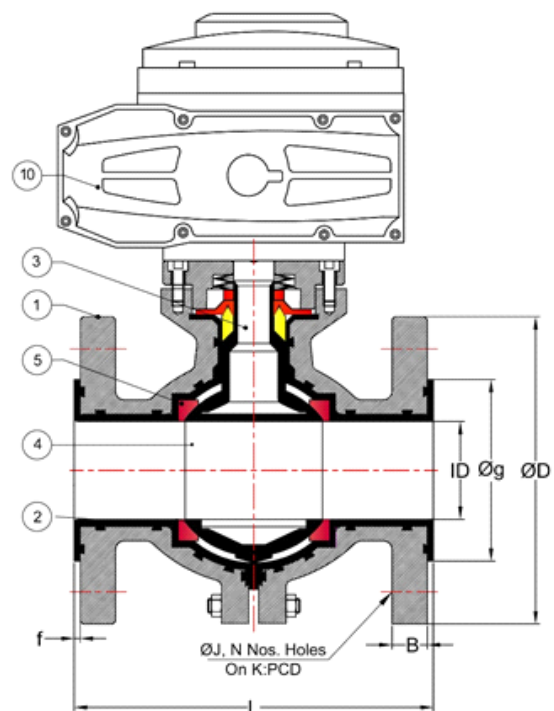

Valve Size										
MM	Inch	ID	L	b	f	Øg	ØD	ØJ	N	PCD
25	1"	24	130.5	12.7	3.5	55	108	16	4	79
40	1.1/2"	38	167	13.5	3	73	127	15	4	98.2
50	2"	49	181	18	4	92	152.5	18.5	4	121
65	2.1/2"	61.8	206	21	4	104.5	177.75	19	4	140
80	3"	74	207	22	5.5	126	190	19	4	152.4
100	4"	94	226	22	5	158	228.5	19	8	190

Optional electrical actuator on/off, modulating and integral starter on above valves



For detailed information refer page no. : XX to XX

For detailed information refer page no. : XX to XX

For detailed information refer page no. : XX to XX