

# Motorized 3 PCS Ball Valve Screwed End / Flanged End ASA 150#

Pneutork make electrical on/off, modulating, integral starter operated 3 pcs design WCB/CF8/CF8M ball valve.



## Size Range · ½" to 8" (15MM TO 200MM)

### Special Features

Design and Manufacturers	ASME B 16.34
Valve Face to Face Dimension	ASME B 16.10
Flange standard Conformity	ASME B 16.5 Class 150#, 300#
Inspection & Testing	API 598

### Optional Model

- » PTL MODEL  
ON/OFF, MODULATING, INTEGRAL STARTER
- » AUQ MODEL EXPLOSION PROOF  
ON/OFF, MODULATING, INTEGRAL STARTER
- » PHQ MODEL EXPLOSION PROOF  
ON/OFF, MODULATING, INTEGRAL STARTER

Item	Type of Test	Testing Pressure	Working Pressure	Operating Temperature High. Temp. On Request
Valve body Screwed	Hydraulic	450 PSIG	315 PSIG	Max. 180°C
Valve body Flanged 150#	Hydraulic	450 PSIG	315 PSIG	MAX. 180°C
Valve body Flanged 300#	Hydraulic	1125 PSIG	815 PSIG	Max. 180°C

No.	Description	Material
1	Body	WCB / S.S. 304 / S.S. 316
2	End Connector	WCB / S.S. 304 / S.S. 316
3	Ball	S.S. 304 / S.S. 316
4	Ball Seat	PTFE / CFT / GFT
5	Stem Pin	AISI 410 / S.S. 304 / S.S. 316
6	Gland With Bush	S.S. 304
7	Stem Seat	PTFE / CFT / GFT
8	Stud & Nut	M.S. / S.S.
9	Electrical Actuator	Standard

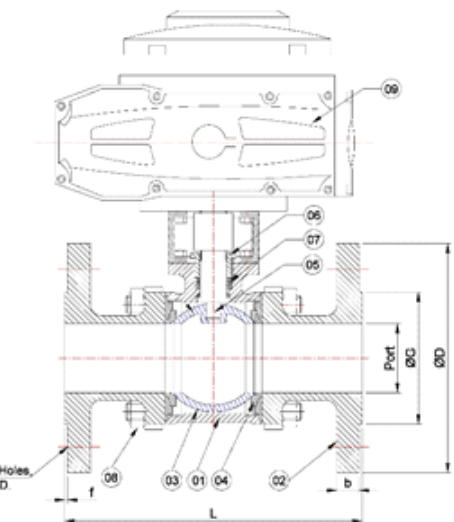
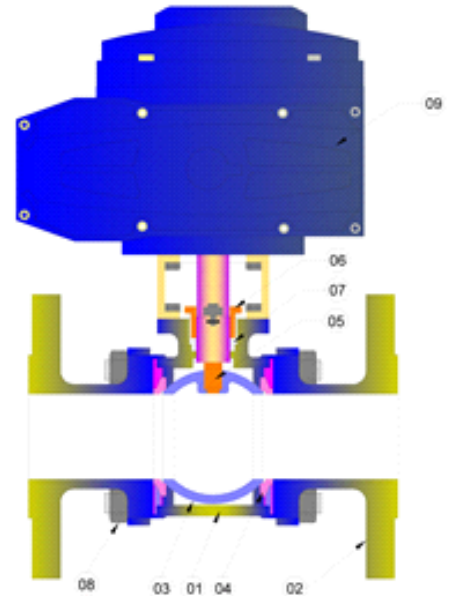

### All Dimension are in mm.

150#									
Valve Size	Port	L	ØD	b	Øg	f	ØJ	f	PSD
Tolerance	±1mm	±3mm	±2mm	±2mm	±1mm				±1.5mm
1/2" (15MM)	13	108	90	8	34.9	2	15.9	4	60.3
3/4" (20MM)	19	117	100	8.9	42.9	2	15.9	4	69.9
1" (25MM)	25	127	110	9.6	50.8	2	15.9	4	79.4
1.1/4" (32MM)	32	140	115	11.2	63.5	2	15.9	4	88.9
1.1/2" (40MM)	38	165	125	12.7	73	2	15.9	4	98.4
2" (50MM)	49	178	150	14.3	92.1	2	19.05	4	120.7
2.1/2" (65MM)	62	190	180	15.9	104.8	2	19.05	4	139.7
3" (80MM)	74	203	190	17.5	127	2	19.05	4	152.4
4" (100MM)	100	229	230	22.3	157.2	2	19.05	8	190.5
5" (125MM)	125	254	255	22.3	185.7	2	22.2	8	215.9
6" (150MM)	150	267	280	23.9	215.9	2	22.2	8	241.3
8" (200MM)	201	292	345	27	269.9	2	22.2	8	298.5

300#									
Valve Size	Port	L	ØD	b	Øg	f	ØJ	f	PSD
Tolerance	±1mm	±3mm	±2mm	±2mm	±1mm				±1.5mm
1/2" (15MM)	13	140	95	12.7	34.9	2	15.9	4	66.7
3/4" (20MM)	19	152	115	14.3	42.9	2	19.05	4	82.6
1" (25MM)	25	165	125	15.9	50.8	2	19.05	4	88.9
1.1/4" (32MM)	32	178	135	17.5	63.5	2	19.05	4	98.4
1.1/2" (40MM)	38	190	155	19.1	73	2	22.2	4	114.3
2" (50MM)	49	216	165	20.7	92.1	2	19.05	8	127
2.1/2" (65MM)	62	241	190	23.9	104.8	2	22.2	8	149.2
3" (80MM)	74	282	210	27	127	2	22.2	8	168.3
4" (100MM)	100	305	255	30.2	157.2	2	22.2	8	200
5" (125MM)	125	381	280	33.4	185.7	2	22.2	8	235
6" (150MM)	150	403	320	35	215.9	2	22.2	12	269.9
8" (200MM)	201	419	380	39.7	269.9	2	25.4	12	330.2