

A pneumatic rack and pinion actuator is a type of device used in industrial automation and control systems to convert the linear motion of compressed air into rotary motion. This actuator is commonly employed to control valves in various applications, such as in the oil and gas industry, chemical processing plants, water treatment facilities, and other industrial settings.

Here's a brief explanation of the key components and working principle of a pneumatic rack and pinion actuator:

## ▶ Rack and Pinion Mechanism

**Rack:** The rack is a linear gear with teeth cut into its surface. It typically moves back and forth linearly.

**Pinion:** The pinion is a small gear that engages with the teeth of the rack. When the pinion rotates, it causes the rack to move linearly.

## ▶ Actuator Body

The actuator body houses the rack and pinion mechanism, providing support and alignment for the components.

## ▶ Pneumatic Cylinder

The pneumatic cylinder is a crucial part of the actuator. It contains a piston that moves back and forth inside the cylinder when Compressed air is introduced. The movement of the piston is what drives the rack and pinion mechanism.

## ▶ Compressed Air Inlet/Outlet

Compressed air is supplied to the pneumatic cylinder through an inlet. The outlet allows the air to be exhausted.

## ▶ Directional Control Valve

A directional control valve is used to control the flow of compressed air to the pneumatic cylinder. By manipulating the valve, operators can control the direction of movement of the actuator (extend or retract).

## ▶ Working Principle

### ▶ Extension

When compressed air is directed to one side of the piston inside the pneumatic cylinder, it pushes the piston, causing the rack and pinion mechanism to move linearly. This linear motion is then converted into rotary motion, rotating the output shaft of the actuator.

### ▶ Retraction

When compressed air is directed to the other side of the piston, it pulls the piston back, reversing the linear motion of the rack and pinion mechanism and causing the output shaft to rotate in the opposite direction.

Pneumatic rack and pinion actuators are known for their simplicity, reliability, and quick response time. They are commonly used in applications where a fast and efficient valve control is required.

TM



## ▶ PERFORMANCE FEATURE

■ Actuators ■ Positioners ■ Limit Switch

### ▶ INDICATOR

The indicator confirms to VID/VIE3845 namur standard, which is convenient for installing limit switch, positioned and other accessories

### ▶ OUTPUT SHAFT

The design of the one-body forging and pressing output shaft of nickel-plated alloy steel is in accordance with NAMUR,ISO5211 and DIN3337 standard. Special standards can be customized according to the customer.

### ▶ CYLINDER BLOCK

It is made of high quality aluminium alloy extrusion, the surface is coated with hard anodic oxidation and Teflon coating.

### ▶ END COVER

Aluminium alloy die casting, surface with anodic hardening treatment and metal polyester coating.

### ▶ PISTON

Cast aluminum with hard oxidation.

### ▶ Adjustment Bolt

Two independent adjustment bolts realize accurate adjustment within  $\pm 50$  of the angle of the valve opening and closing.

### ▶ Piston Ring

Use low friction and long life composite material, convenient repair and replace.

### ▶ Seal

Use nitrile rubber under normal temperature, special seal is available according to the customer's requirement for high temperature and low temperature.

### ▶ Air connection

It complies with NAMUR standard and can be directly mounted with NAMUR standard solenoid valve.

### ▶ Fasteners

All fastener are made of stainless steel.

## COMPONENTS MATERIAL

SR.NO.	NAME	QTY OF EACH UNIT	STANDARD MATERIAL	MATERIAL OF SELECTABLE
1	Left cover	1	Aluminium Die Casting	
2	"O" ring (cover)	2	NBR	FPM/Q
3	Piston Ring	2	POM	
4	"O" ring (Piston)	2	NBR	FPM/Q
5	Piston	2	Aluminium Die Casting	
6	Bolt	1	ABS	
7	Main body of the Indicator	1	ABS	
8	Shaft Ring	1	Stainless Steel	
9	Gasket	1	POM	
10	Block	1	Aluminum Extrusion	
11	Guide Ring	2	Pa66	
12	Right Cover	1	Aluminium Die Casting	
13	End Cover Bolt	8	Stainless Steel	
14	"O" ring (Adjustable bolt)	2	NBR	FPM/Q
15	Gasket	2	Stainless Steel	
16	Nut	2	Stainless Steel	
17	Adjustment Bolt	1	Stainless Steel	
18	"O" Ring (at the top of the shaft)	1	NBR	
19	Bearing (at the top of the shaft)	1	POM	
20	Gasket	1	POM	
21	Adjustment Cam	1	Carbonsteel	
22	Output Shaft	1	Carbonsteel	
23	Bearing (Output shaft bottom)	1	POM	
24	"O" ring (output shaft bottom)	1	NBR	FPM/Q

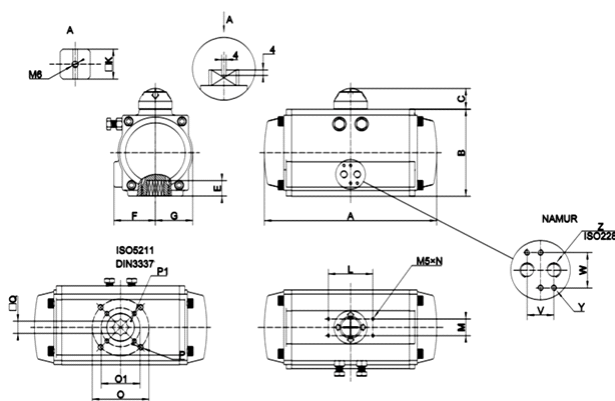
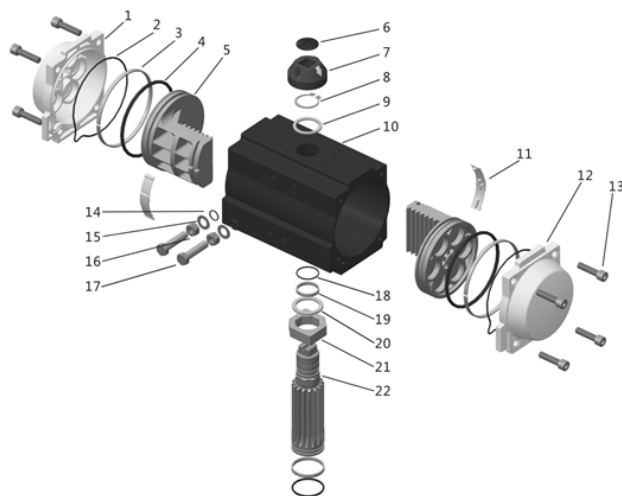

## Actuators Positioners

## DIMENSION AND CONNECTION IN MM

Model	Pt052	Pt063	Pt075	Pt083	Pt092	Pt105	Pt125	Pt140	Pt160	Pt190	Pt210	Pt240	Pt270	Pt300	Pt350	Pt400
ISO FLANGE	F03/F05	F05/F07	F05/F07	F05/F07	F07/F10	F07/F10	F07/F10	F10/F12	F10/F12	F14	F14	F16	F16	F16	F16/25	F16/25
A	154	176	188	211	244	277	310	394	458	523	526	602	718	760	920	940
B	73	89	101	110	118	135	157	175	198	232	257	289	326	350	410	466
C	25	25	25	25	25	25	39	39	39	39	39	30	30	30	30	30
E	13	17	17	17	20	25	27	30	30	38	38	50	50	50	50	50
F	41	47	53	57	60	64	75	75	86	103	113	130	147	174	195	260
G	30	36	43	47	50	58	67	75	86	103	113	130	147	162	190	260
L	80	80	80	80	80	80	80	130	130	130	130	130	130	130	130	130
M	30	30	30	30	30	30	30	30	30	30	30	30	30	30	30	30
N	4-M5X9	4-M5X9	4-M5X9	4-M5X9	4-M5X9	4-M5X9	4-M5X9	4-M5X9	4-M5X9	4-M5X9	4-M5X9	4-M5X9	4-M5X9	4-M5X9	4-M5X9	4-M5X9
O	50															
P	4-M5X9	4-M8X12	4-M8X12	4-M8X12	4-M8X15	4-M8X15	4-M8X15	4-M8X18	4-M8X18	4-M8X24	4-M8X24	4-M8X25	4-M8X25	4-M8X25	4-M8X25	4-M8X25
O1	36	50	50	50	70	70	70	102	102							
P1	4-M5X8	4-M6X9	4-M6X9	4-M6X9	4-M6X12	4-M6X12	4-M6X12	4-M6X12	4-M6X12	4-M6X15	4-M6X15	4-M6X15	4-M6X15	4-M6X15	4-M6X15	4-M6X15
Q	11	14	14	17	17	22	22	27	27	36	36	46	46	46	46	46
V	24	24	24	24	24	24	24	24	24	24	24	24	40	40	40	40
W	36	36	36	36	36	36	36	36	36	36	36	36	45	45	45	45
Y	4-M5X9	4-M5X9	4-M5X9	4-M5X9	4-M5X9	4-M5X9	4-M5X9	4-M5X9	4-M5X9	4-M5X9	4-M5X9	4-M5X10	4-M5X10	4-M5X10	4-M5X10	4-M5X10
Z	G1/4"	G1/4"	G1/4"	G1/4"	G1/4"	G1/4"	G1/4"	G1/4"	G1/4"	G1/4"	G1/4"	G1/4"	G1/2"	G1/2"	G1/2"	G1/2"

## ► Output torque (double acting)

Actuator Model	2.0 bar	2.5 bar	3.0 bar	4.0 bar	4.5 bar	5.0 bar	5.5 bar	6.0 bar	7.0 bar	8.0 bar
PT052D	8	10	12	16	18	20	22	24	28	32
PT063D	15	18	22	29	33	36	40	44	51	58
PT075D	20	25	30	40	45	50	55	60	70	80
PT083D	31	39	47	63	70	78	86	94	111	125
PT092D	45	56	68	90	102	113	124	135	158	181
PT105D	66	83	99	132	149	165	182	198	351	264
PT125D	100	125	150	200	226	251	276	301	351	401
PT140D	171	214	256	342	385	427	470	513	598	684
PT160D	266	332	399	532	598	665	731	798	931	1064
PT190D	420	532	638	851	958	1064	1170	1277	1490	1702
PT210D	532	665	798	1064	1197	1330	1463	1596	1862	2128
PT240D	769	962	1154	1539	1731	1924	2116	2308	2693	3078
PT270D	1170	1462	1750	2339	2632	2924	3216	3509	4094	4679
PT300D	1526	1908	2289	3052	3434	3815	4197	4578	5341	6104
PT350D	2285	2856	3427	4570	5141	5712	6283	6854	7997	9139
PT400D	3256	4070	4884	6512	7326	8140	8954	9768	11396	13024

## ► SINGLE ACTING OUT PUT TORQUE (SPRING RETURN)(NM)

Actuator Model	SPRING QUANTITY	4.0 BAR		5.0 BAR		6.0 BAR		7.0 BAR		8.0 BAR		SPRING RETURN TORQUE	
		0° START	90° END	0° START	90° END	0° START	90° END	0° START	90° END	0° START	90° END	0° START	90° END
PT052D	10	7.4	3.6	11.5	6.7	15.5	11.6	19.5	15.6	/	/	12.4	8.5
PT063D	10	1.4	8.2	22.8	15.6	30	22.8	37.3	30.1	44.7	37.4	20.9	13.7
PT075D	10	19	11.1	28.8	21.2	39	31.2	49.1	41.2	59.1	51.2	29	21.1
PT083D	10	31	16.	46.7	32.3	62.4	48	78.1	63.7	93.8	79.3	46	31.6
PT092D	10	43.6	21.5	66.2	44.1	88.8	66.7	111.3	89.2	134	11.8	68.7	46.7
PT105D	10	68.9	33.4	102	66.5	135.1	99.6	161.8	123.1	201.2	165.7	98.4	63.3
PT125D	10	96	44	146	94	196	144	247	194	297	245	157	105
PT140D	10	170	84	256	169	314	255	427	340	512	426	258	172
PT160D	10	253	115	386	248	519	381	652	514	785	647	417	279
PT190D	10	451	233	664	446	877	658	1090	871	1302	1084	618	400
PT210D	10	514	304	780	570	1046	836	1312	1102	1578	1368	760	500
PT240D	10	718	431	1103	816	1488	1201	1872	1586	2257	1970	1108	821
PT270D	10	1220	767	1805	1352	2390	1937	2974	2521	3560	3107	1572	1119
PT300D	10	1430	695	2355	1693	2956	2221	3719	2984	4482	3747	2122	1460
PT350D	10	1963	787	3105	1929	4247	3071	5390	4214	6532	5356	3405	2346
PT400D	10	3012	1025	4640	2653	6268	4281	7895	5908	9523	7536	4938	3149