

# Pneumatic Rotary Actuator Operated PP Ball Valve



## Size Range

1/2" TO 3" SCREWED END, 1/2" TO 12" FLANGED END

Hydro test pressure :

Body	Seat	Temperature
150 PSI	150 PSI	100°C

PVDF for Highly Acidic Media Available on Request.

## Accessories

- » On/Off Actuator
- » NAMUR Standard solenoid valve all standard coil voltage (Flame proof solenoid coil on request)
- » Pneumatic & Electro pneumatic valve positioner.
- » Declutch able Manual Over ride
- » Limit Switch for on/off indication at panel board.
- » Air filter + Regulator combination with pressure Gauge
- » Air Lock Valve

No.	Description	Material
1	Body	Polypropylene
2	End Connector	Polypropylene
3	Ball	Polypropylene
4	Ball Seat	PTFE
5	Stem Pin	S. S. 304
6	Body Seat	PTFE
7	Adaptor	S. S. 304
8	Stem O Ring	NBR
9	Clamp	S. S. 304
10	Bolt	S. S. 304
11	Washer	S. S. 304
12	Actuator	STD.

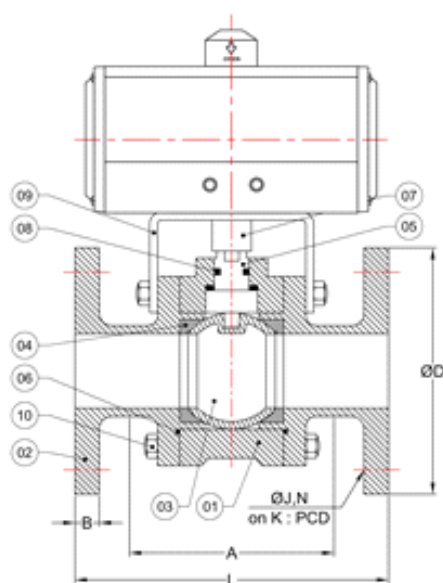
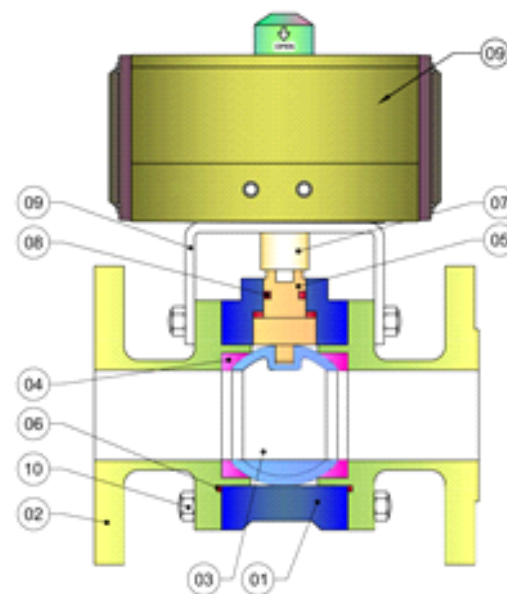

All Dimension are in mm.

Valve Size		Screwed	Flanged					
MM	Inch	A	L	b	ØD	ØJ	N	K:PCD
15	1/2"	127	130	16.5	96	15.9	4	60.3
20	3/4"	139	132	14.5	102	15.9	4	69.9
25	1"	150	152	18.5	121	15.9	4	79.4
32	1.1/4"	172	162	18	124	15.9	4	88.9
40	1.1/2"	172	170	18.5	140	15.9	4	98.4
50	2"	209	209	22.5	165	19.05	4	120.7
65	2.1/2"	248	230	22.5	184	19.05	4	139.7
80	3"	280	254	24	203	19.05	4	152.4
100	4"	N/A	310	27	229	19.05	4	190.5
150	6"	N/A	477	28	305	22.5	8	241.3
200	8"	N/A	477	30	368	22.5	8	298.5
250	10"	N/A	560	31	432	25.4	8	362
300	12"	N/A	560	31	489	25.4	8	431.8