

Intelligent Process Control

Build a Quality

Adopt high strength sintering processed glass lens, the indicator window is more beautiful and smooth.

Adopt circular stop flameproof surface, better flameproof and more reliable

The electric limit stroke micro-adjustment device makes the electric limit adjustment simpler and more accurate.

Explosive-proof grade Exd II CT6Gb, meets the flameproof requirements of more than 90% explosive gas environment.

The protection grade is IP68, which solves the problem of low protection grade and poor performance of traditional flameproof products.

ISO5211 mounting

High quality aluminum alloy shell, cylindrical and streamlined design, exquisite and beautiful appearance.

Explosionproof overview

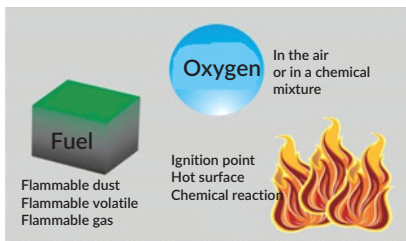

What is explosion?

The prerequisite for triggering an explosion is that the explosive material must be mixed with oxygen to a certain extent to cause a chemical reaction under appropriate ignition conditions. If the speed of reaction exceeds the speed of sound, it is defined as an explosion.

The explosive mixture that accumulates to a certain degree explodes suddenly and causes destruction effect in the form of explosion wave.

What is explosion-proof?



An explosion can be prevented if any one of the above three conditions is restricted. At many service sites, the presence of explosive substances and oxygen is difficult to avoid, so the source of ignition must be limited.

Electrical equipment is a potential source of ignition. When the machine is running, it causes surface temperature rise, electrostatic release or sparks caused by instantaneous current.

The explosion-proof electrical equipment is designed to avoid excessive surface temperature and spark during its operation. Therefore, explosion-proof electrical equipment will not become a potential source of ignition.

Classification of potentially explosive environments

Generally, electrical equipment used in explosive gas environments can be divided into two categories

Class I Electrical equipment for coal mine

Class II Electrical equipment for explosive gas environments other than coal mine

For Class II electrical equipment, explosive gas can be divided into three explosive levels: IIA, IIB and IIC according to the maximum test safety gap (flameproof type) and minimum test ignition current (intrinsically safe type). Class IIB equipment can be applied to the service conditions of IIA equipment, and class IIC equipment can be applied to the service conditions of IIA and IIB equipment.

For Class II electrical equipment, according to the maximum allowable surface temperature can be divided into T1 (450 °C), T2 (300 °C), T4(135 °C), T5(100 °C), T6 (85 °C) six temperature groups, and the high temperature group equipment can be applied to the use of low group conditions.

More than 90% of the explosive gases are contained in the IIA, IIB explosive levels and T1-T4 temperature groups.

		Temperature Group					
		T1(450°)	T2(300°)	T3(200°)	T4(135°)	T5(100°)	T6(85°)
Explosive Level	IIA	Acetone Ethane Phenalin Acetic acid Methanol Propane	Ethyl alcohol Butane Butanol Ethylene 2 ethane	Benzene Diesel Aircraft fuel Fuel Ethane	Acetaldehyde		
	IIB	Gas	Ethylene Ethylene oxide		Diethyl ether		
	IIC	Hydrogen	Acetylene				Carbon, Disulphide

How to achieve explosion-proof?

There are various ways to make electrical equipment suitable for explosive environments, and these methods are described in detail in GB3836, ICE60079, EN50014 and other standards.

PVQ series explosion-proof electric actuators are manufactured in accordance with the explosion-proof type of "flameproof type "(Exd), in line with GB3836.1-2010, GB3836.2-2010 standard requirements.

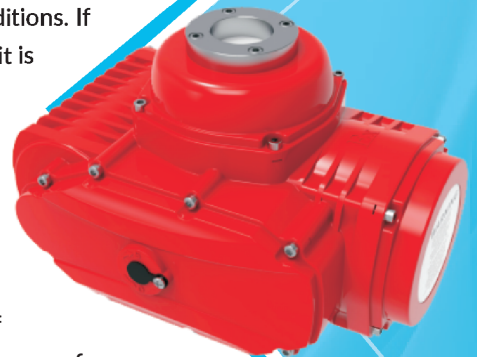

Explosive Level

The flameproof actuators allow explosions to occur inside the equipment. The flameproof surface of the housing is designed to prevent the internal spark or explosion carrier from contacting the outside world. Appropriate flameproof surface clearance and sufficient length of the flameproof surface ensure this. At the same time, the sturdy shell can withstand the high pressure generated by the internal explosion without being damaged

The following parts of PVQ series actuators are designed and manufactured according to flameproof standards.

- ◆ Motor chamber
- ◆ Electrical element chamber
- ◆ Wiring chamber

Explosion-proof Grade

AUQ explosion-proof series electric actuator grade: ExdIICT6Gb

- » Ex-Explosion-proof marking
- » D-Explosion-proof type: flameproof
- » II-Equipment type: other gas environments except coal mine
- » C-Explosive level, this level determines the size (length and clearance) of each flameproof joint of the actuator.
- » T6-Temperature class, the maximum allowable surface temperature of the actuator is 85° C
- » Gb-Explosion protection level of equipment

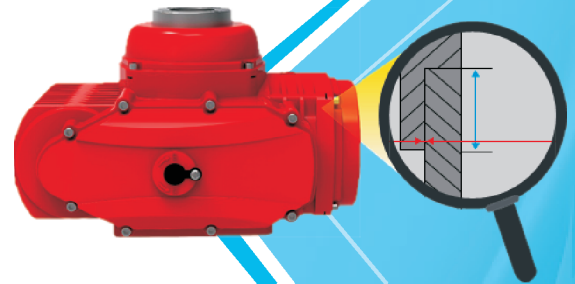

How to use and maintain explosion-proof electrical equipment?

Installation, commissioning, maintenance, repair, and replacement shall be carried out by qualified explosion-proof professionals who have been trained, and shall strictly comply with the requirements of the electrical equipment (operation manual).

The Performance Parameters

Actuator Model	Max Output Torque	Operating Time To 90° S		Motor (W)		Single Phase Rated Current (A)						Weight Kg
		AC	DC	AC	DC	AC24V	AC110V	AC220V	AC380V	DC24V	DC220V	
PVQ005	50	30	10	15	15	2.2	0.48	0.24	0.16	1.2	0.15	3.5
PVQ010	100	30	10	30	25	3.6	0.8	0.4	0.22	1.6	0.2	6
PVQ015	150	30	10	30	25	3.6	0.8	0.4	0.22	1.6	0.2	6
PVQ020	200	30	15	90	70	9	1.8	0.92	0.53	2.6	0.3	12.2
PVQ040	400	30	15	90	70	9	1.8	0.92	0.53	2.6	0.3	12.5
PVQ060	600	30	15	90	70	9	1.8	0.92	0.53	4.5	0.5	12.5
PVQ100	1000	40	25	130	130	12	2.2	1.1	0.6	5.0	0.6	12.5
PVQ200	2000	90	50	300	300	17	2.8	1.4	0.8	6.0	0.8	21
PVQ300	3000	90	50	300	300	17	2.8	1.4	0.8	6.0	0.8	21

Technical Parameters

General Specification

Torque range	50-3000Nm	Optional AUM series for larger torque or faster opening
Body material	Aluminium Die-casting	
Position indicator	The valve position dial shows continuous position changes even when power is off.	

Protection

External protection against corrosion	Coating
	Polyester powder coating in accordance with GBT 18593-2001 standard Optional protection against corrosive conditions
	Screws are stainless steel

Stroke & Limit

Stroke	90° standard (90° ~270° optional)
Limit switch	2xOpen/Close, SPDT, 250VAC10A
Auxiliary limit switch	2xOpen/Close, SPDT, 250VAC10A
Mechanical limit	2 internal adjusting bolts

Mechanical Specifications

Self-lock device	Self-lock by worm and worm gear
Mounting Flange	ISO5211
Output shaft	Inner octagonal type, connect directly to the valve horizontally or vertically
Shock resistance	XYZ10g.o.2~34Hz, 30 minutes
Lubrication	Aluminium-base grease (EP type)
Manual operate	Mechanical clutch
Spanner	Reliable, labor-saving and small

PVQ explosion-proof electric actuator

Electrical Specifications

Motor Power	24/110/220VAC 1Phase, 380/440VAC 3Phase, 12/24/220VDC
Control Power	24/110/220VAC 1Phase, 380/440VAC 3Phase, 12/24/220VDC
Motor	Squirrel-cage asynchronous motor, insulation class H
Fail protection/Operating temperature	Built-in thermal protection, open 120 °C±5 °C/close 97°C±5°C
Heater	25~30W (220VAC) Prevent Condensation
Wiring Hole	2 x G1/2"

EC Directive

Conformance with	Actuator meets the following requirements	
	2014/30/EU EMC	2014/35/EU LVD
	The following coordination criteria:	
	General emission standard for industrial environment EN 61000-6-4	
	General anti-interference standard for industrial environment EN 61000-6-4	
	Electric rotating machinery standard EN 60034-1	

▶ PVQ exterior and internal structure drawing

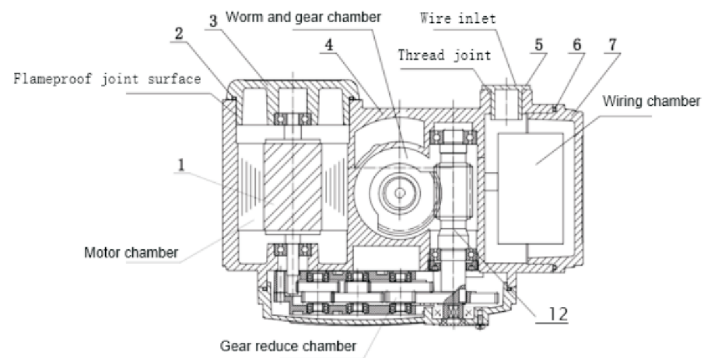
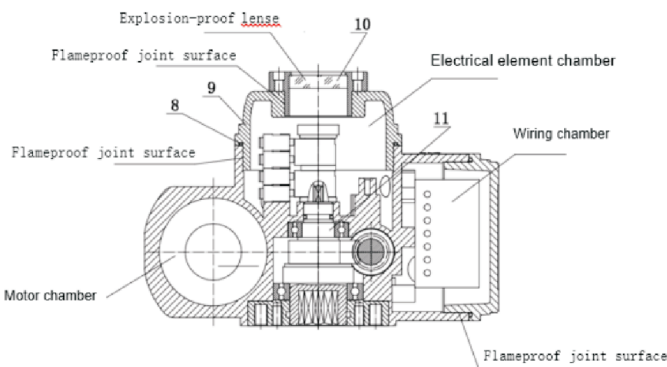

SR.NO.	NAME	MATERIAL	SR.NO.	NAME	MATERIAL
1	Motor rotor shaft	40Cr	7	Terminal cover	ADC12
2	O ring	NBR	8	O ring	NBR
3	Motor cover	ADC12	9	Upper cover	ADC12
4	Shell	ADC12	10	Lense	Soda-lime glass
5	Explosion-proof plug	Nickel plated brass	11	Output shaft	Nickel plated 40Cr
6	O ring	NBR	12	Worm	#45 steel

▶ PVQ exterior structure drawing

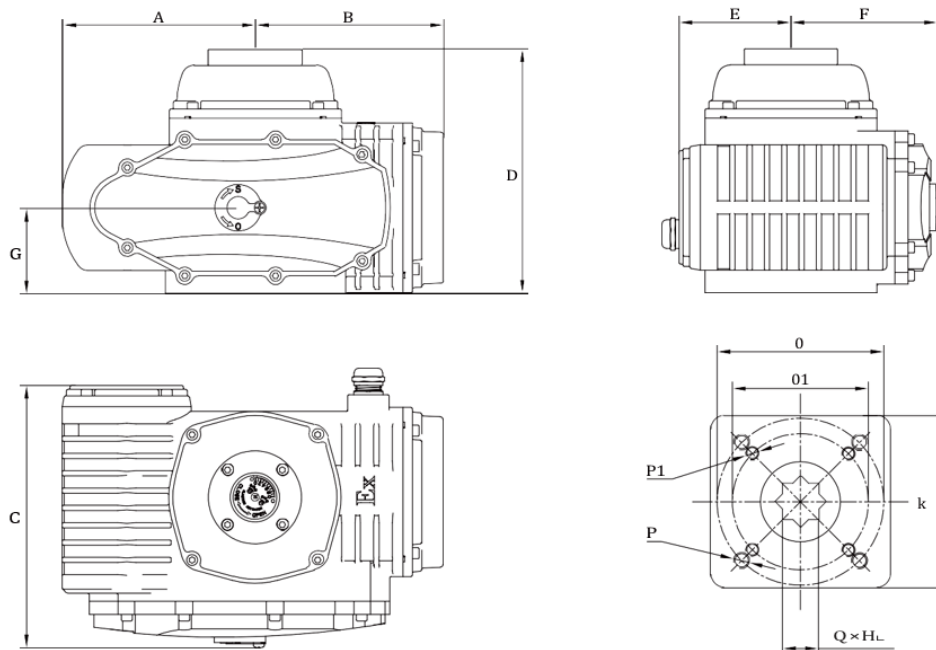

► Dimension and Connection in (mm)

Model	A	B	C	D	E	F	G	K	O	P	01	P1	QxH
PVQ-005	90	102	146	142	66	77	42	80	70	4-M8	50	4-M6	14×19
PVQ-010	106	110	154	155	72	79	45	95	70	4-M8	50	4-M6	17×22
PVQ-015	106	110	154	155	72	79	45	95	70	4-M8	50	4-M6	17×22
PVQ-020	144	141	197	183	84	110	64	129	125	4-M12	102	4-M10	22×24
PVQ-040	144	141	197	183	84	110	64	129	125	4-M12	102	4-M10	22×24
PVQ-060	144	141	197	183	84	110	64	129	125	4-M12	102	4-M10	22×24
PVQ-100	144	141	197	183	84	110	64	129	125	4-M12	102	4-M10	27×29
PVQ-200	175	170	227	211	99	125	73	150	140	4-M16	102	4-M10	36×39
PVQ-300	175	170	227	211	99	125	73	150	140	4-M16	102	4-M10	36×39

► Model Design

PVQ -Ex10B/30S/AC220V



► ON/OFF Actuator

A/B/D/G/H Control circuit

ON/OFF type only has full open and full off limit position, if necessary, can preset the middle position (B/D/G/H). Upon appropriate instruction, the actuator will drive the valve to a fully open or fully closed or intermediate position.

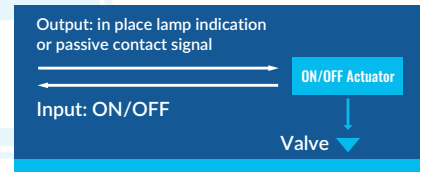

► Feedback Actuator

C/D/F Control circuit

In the process of driving the valve, the actuator feedback valve position signal to the central control system at the same time. C/D feedback resistance valve position signal, F feedback analog valve position signal.

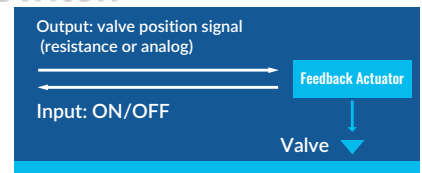

► Modulating Actuator

E Control circuit

The servo controller is placed inside the actuator and drives the valve to the appropriate opening position according to the change of the controlled variables (flow, pressure, temperature, liquid level) in the pipeline and accepts the instructions of the central control system.

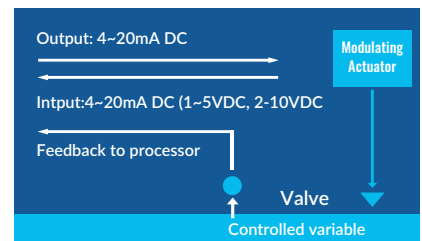

► Motor

Due to the working characteristics of the valve, it is required that the actuator in the valve open, close, and any position in the middle have full load starting capacity, which requires the motor of the actuator has a higher starting torque. At the same time, due to the flow (opening) adjustment needs, the motor must also have a small moment of inertia. PVA series electric actuator motors are specially designed for these requirements.

When the actuator is stuck, the temperature of the motor will rise rapidly. When the motor temperature rises to 105°C, the PTC overheat protector embedded in the motor windings will cut off the circuit to protect the motor and the control system. When the temperature of the motor drops to 80-90°C, the circuit will be connected again.

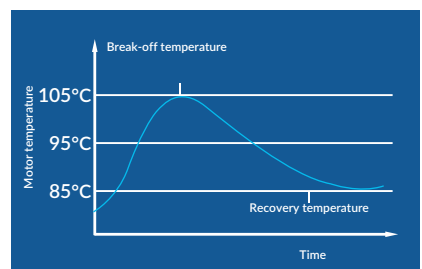

▶ Servo Controller

Unique circuit design, all imported industrial electronic components, the use of modern circuit board manufacturing process, ensure the servo controller of AUQ actuator of high quality and high reliability. The whole circuit board is protected by resin plastic seal, anti-seismic and moisture-proof performance is better. Unique electronic braking function, making the actuator positioning without vibration, damping characteristics for 0 cycles (no more than 3.5 cycles according to the standard)

▶ Electrical Limit Stroke Micro adjustment Device

Only a straight screwdriver is needed to easily adjust the electric limit stroke of the actuator in the open and close directions. At the same time, the unique micro adjustment function makes the adjustment of electric limit stroke more accurate.

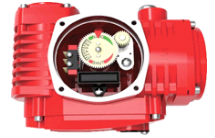

▶ Electrical Limit Function

Electrical stroke limit function: when the actuator reaches the full open, full close limit position or the set intermediate position, the built-in electric limit switch will cut off the circuit to protect the actuator.

Output shaft mechanical limit function: when the electric stroke limit function fails, the actuator output shaft will be locked by the mechanical limit device to protect the valve from damage

The diagram shows the position relationship between electrical limit and mechanical limit.

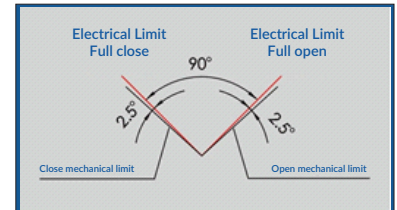

▶ Overtorque protection function (optional)

When the valve is stuck in the working process (middle position) due to impurities in the pipeline foreign matter or other reasons, the output torque of the actuator will increase rapidly, reach the set value (jump torque), the torque switch will disconnect the circuit, so as to protect the valve and actuator from damage.

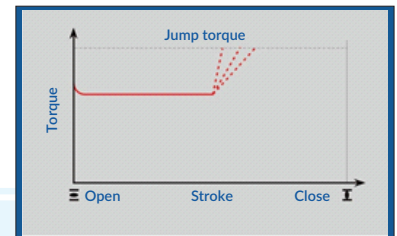

▶ Heating dehumidification function (optional)

The electrical chamber of PVQ actuator can be equipped with PTC electronic heating element, which is used in the place where the temperature difference between day and night is large and relatively humid, to prevent the damage of electrical components caused by condensation and frost. The heater is continuous working and charged, even if the actuator is not running.

PVQ explosion-proof electric actuator

